

# LISTA RICAMBI

## ELEVAH40MOVE & ELEVAH40MOVE PICKING



# SPECIFICARE LA MATRICOLA DELLA MACCHINA

## ELEVAH40MOVE & ELEVAH40MOVE PICKING

N°	Codice:	Descrizione:			
1	CAR.ELE40	Carro base completo			
2	2TAP.040	Tappo a pera d.40			
3	***	Telaio cestello			
4	2CAREN20	Carena inferiore piano			
5	2CAREN16	Carena posteriore			
6	2PARACOL	Sfera cavo			
7	2RUO150E	Ruota d. 150x28			
8	2ANEL20B	Borchia di fissaggio			
9	2MOLLALV	Molla bolla di livello			
10	2FIALALV	Bolla di livello			

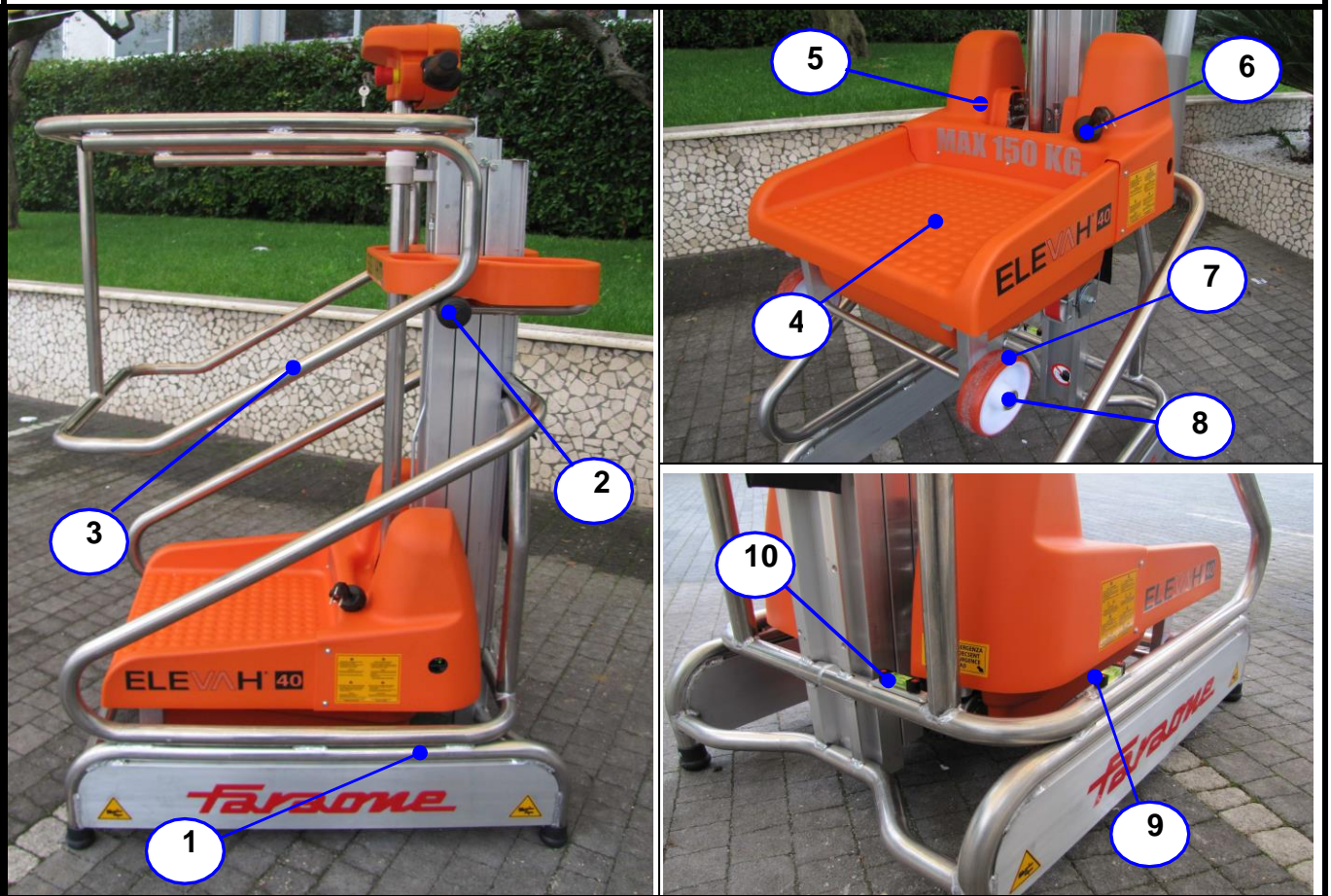

# ELEVAH40MOVE & ELEVAH40MOVE PICKING

N°	Codice:	Descrizione:			
11	2CAREN19	Vaschetta portaoggetti			
12	2CAREN17	Carena frontale comandi			
13	2PULS.CO	Pulsante movimenti			
14	2PULSEM5	Pulsante di emergenza a chiave			
15	2MANOACC	Manipolatore comandi			
16	ZSTEC.N9	Stecca di blocco			
17	2BOCCO20	Boccola di contrasto			
18	2BOCCO40	Guida sterzo superiore			
19	2CAV1255E	Cavetto in acciaio			
20	2CAREN18	Carena posteriore comandi			
21	2CARRUCO	Puleggia guida cavo			
22	***	Lamiera protezione cavo			
23	2SACCAEL	Sacca portadocumenti			
24	***	Lamiera protezione posteriore			
25	2CILH40A	Cilindro idraulico			

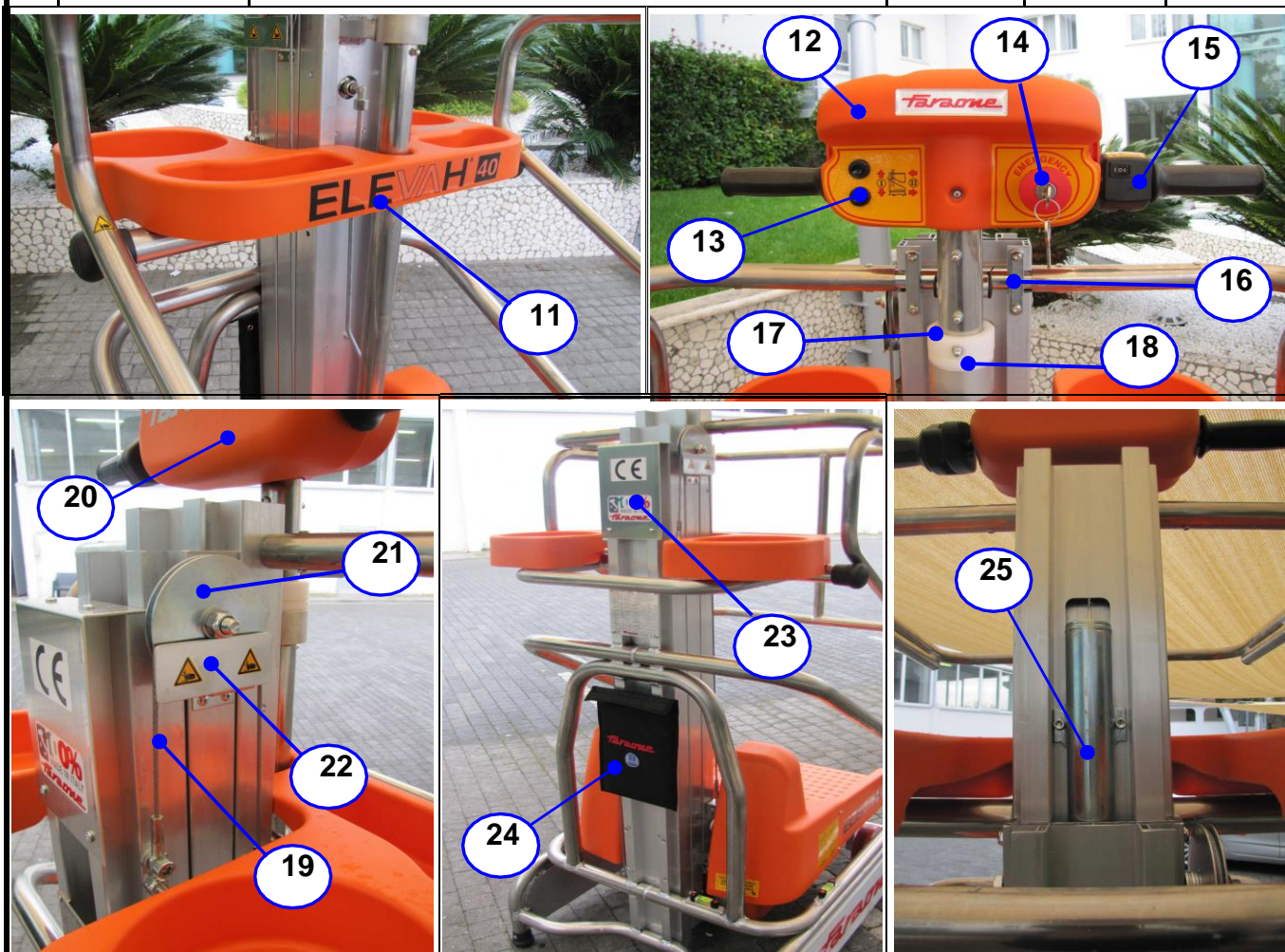

# ELEVAH40MOVE & ELEVAH40MOVE PICKING

N°	Codice:	Descrizione:			
26	2MOTORU5	Motoruota completa			
27	2PERNO14	Perno di blocco			
28	***	Elettrofreno MINIG			
29	2CINGH07	Cinghia di sollevamento			
30	2RULLO62	Rullo cinghia			

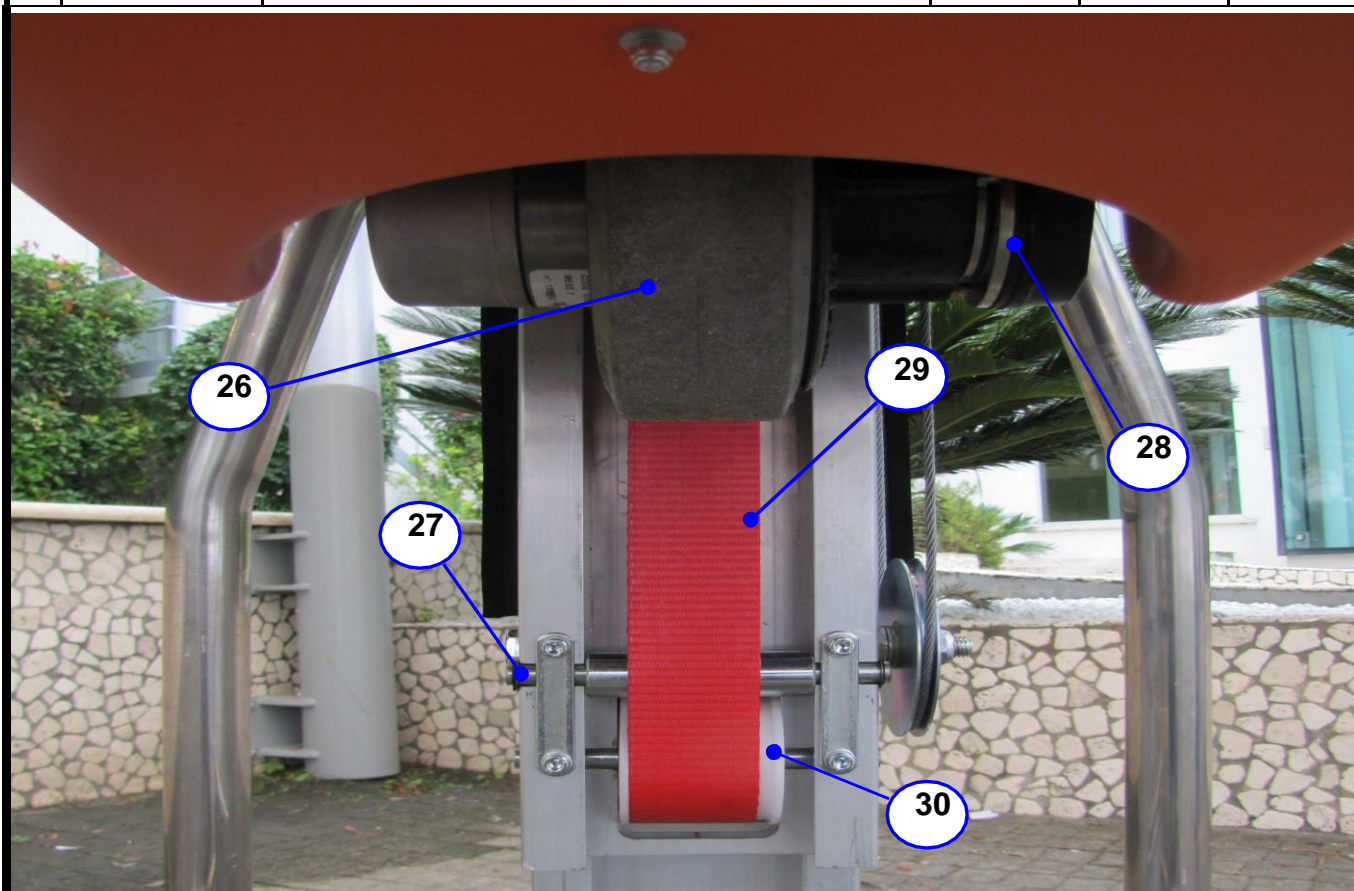

# ELEVAH40MOVE & ELEVAH40MOVE PICKING

N°	Codice:	Descrizione:			
31	CAR.ELE40	Carro base completo			
32	SSFO0042	2° Sfilo ELEVAH40			
33	2CEST.40	Cestello completo			
34	STERZO.40	Sterzo completo			
35	2MOLLA18	Molla trazione			
36	2MICRO14	Micro di blocco			
37	***	Supporto micro			
38	2BOCC.15	Boccola molla			
39	2CAR.B40	Caricabatterie			
40	2BOCCO46	Guida sterzo inferiore			

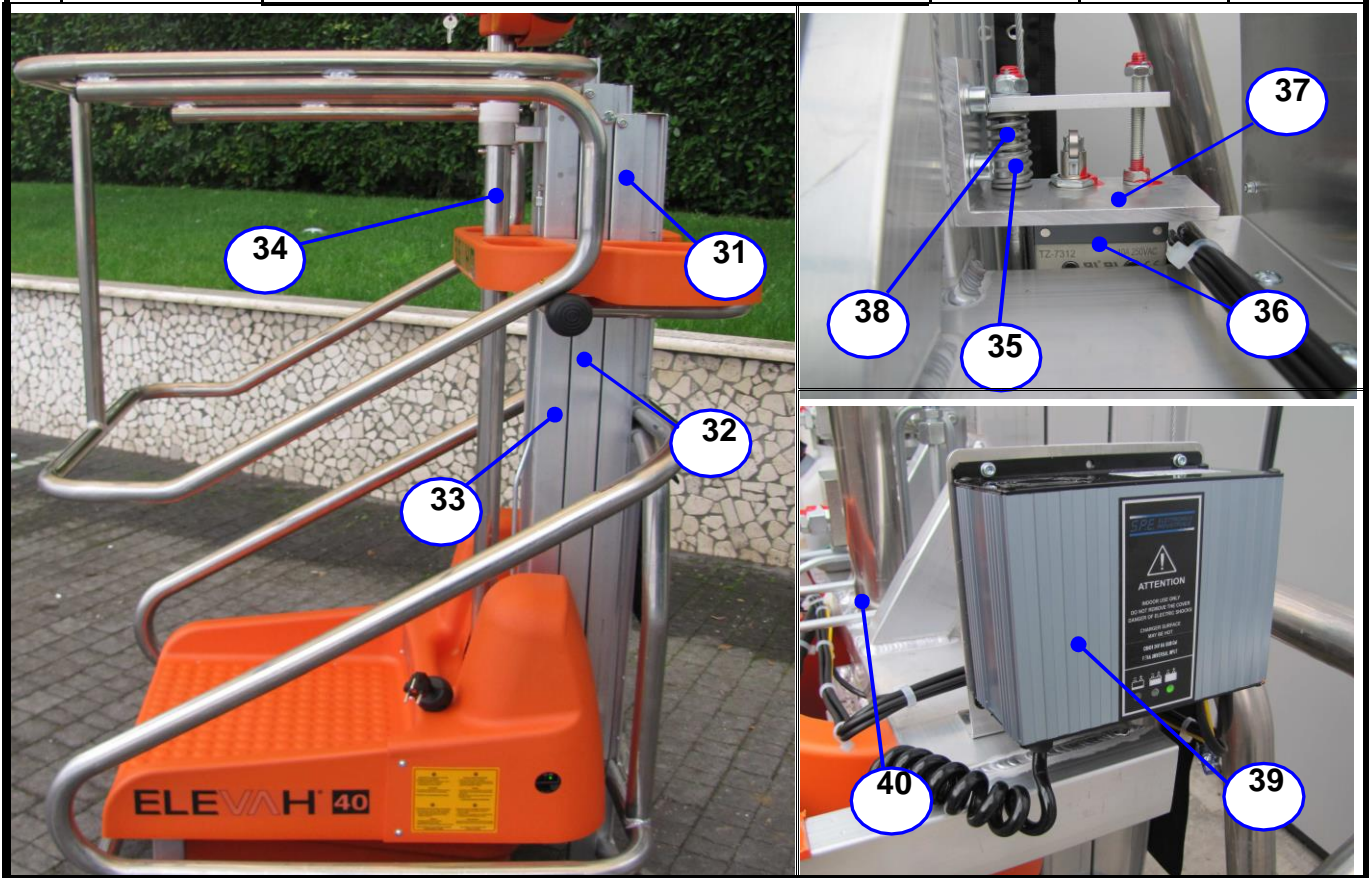

# ELEVAH40MOVE & ELEVAH40MOVE PICKING

N°	Codice:	Descrizione:			
41	2SUPCING	Supporto cinghia			
42	2TENDITO	Tenditore cinghia			
43	2RULLO16	Rullo di scorrimento			
44	2PERNO16	Perno rullo di scorrimento			
45	2PERNO61	Perno attacco cinghia			

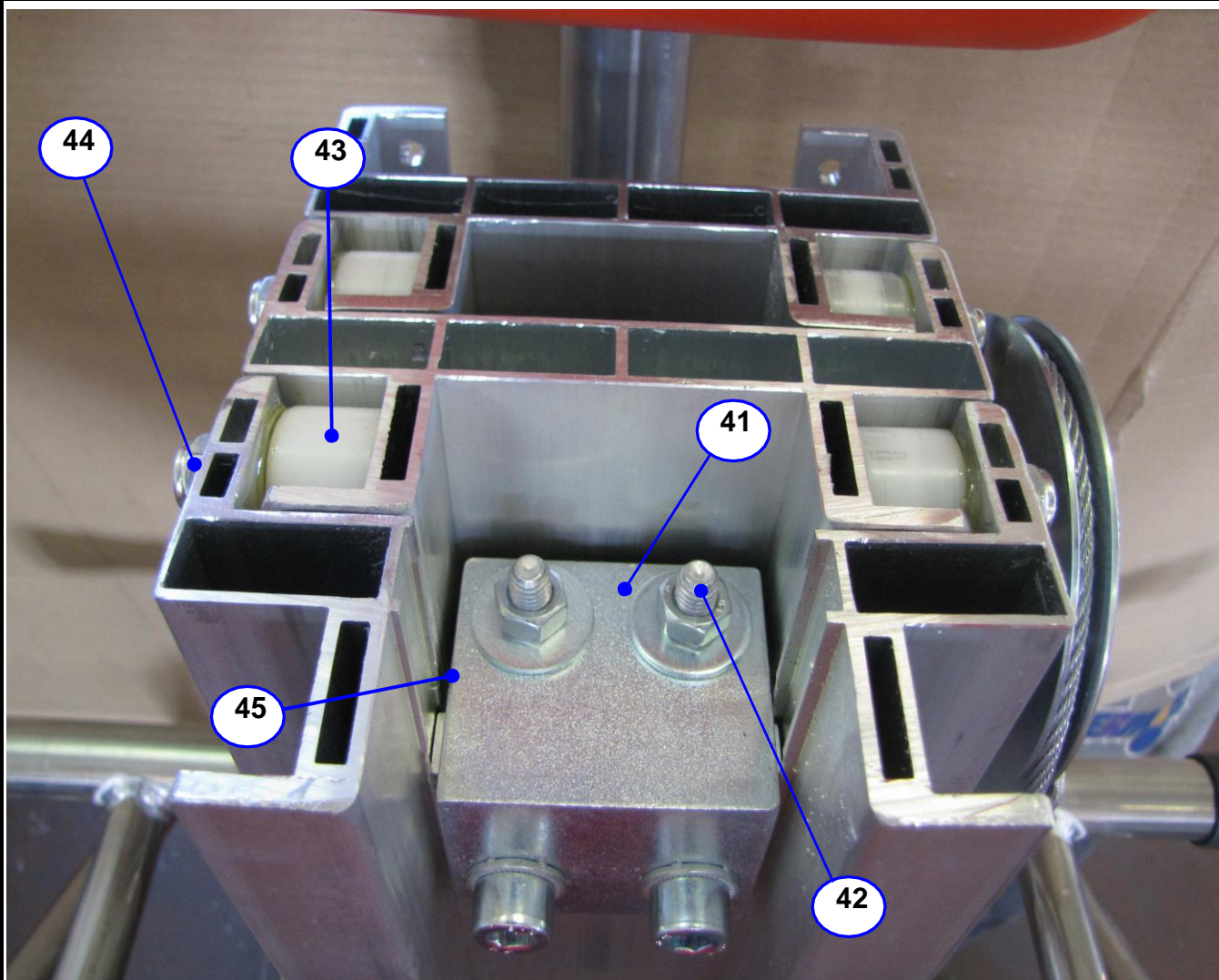

# ELEVAH40MOVE & ELEVAH40MOVE PICKING

N°	Codice:	Descrizione:			
46	2CAREN15	Vano portabatterie			
47	2BAT.33A	Batterie 12V-33 A			
48	2CINT400	Cinghia batteria			
49	2SCHE4F	Scheda elettronica			
50	2FUS.50A	Fusibile 50A			

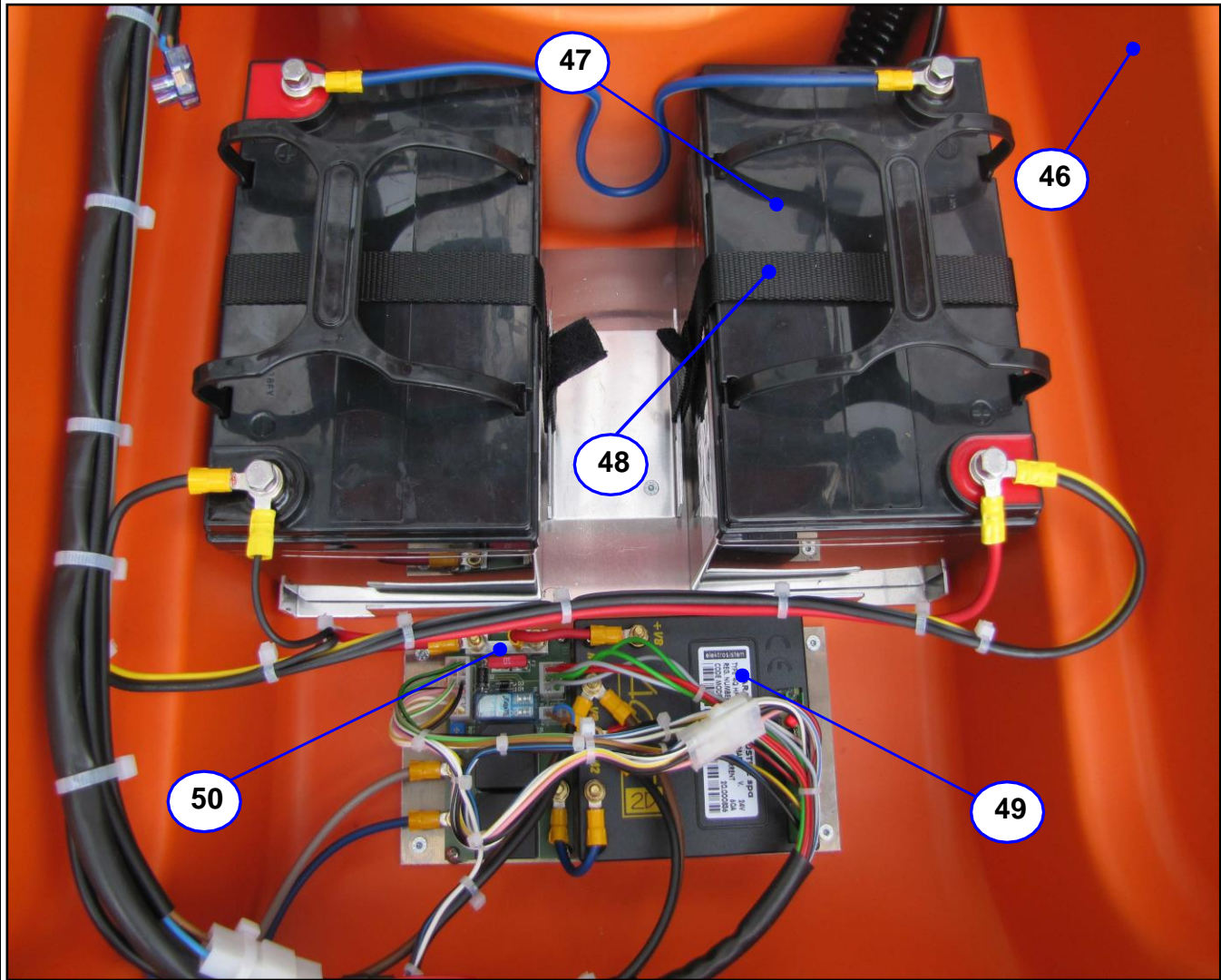

# ELEVAH40MOVE & ELEVAH40MOVE PICKING

N°	Codice:	Descrizione:			
51	2PIASTR8	Piastra nylon per scorrimento			
52	2MANOP6Z	Manopola di blocco			
53	***	Supporto piano Picking			
54	***	Piano Picking			
55	***	Tubo piano picking			
56	2ANEL.25	Anello in acciaio			
57	2MOLLA40	Molla interna			
58	2NOTTOL6	Perno di blocco			

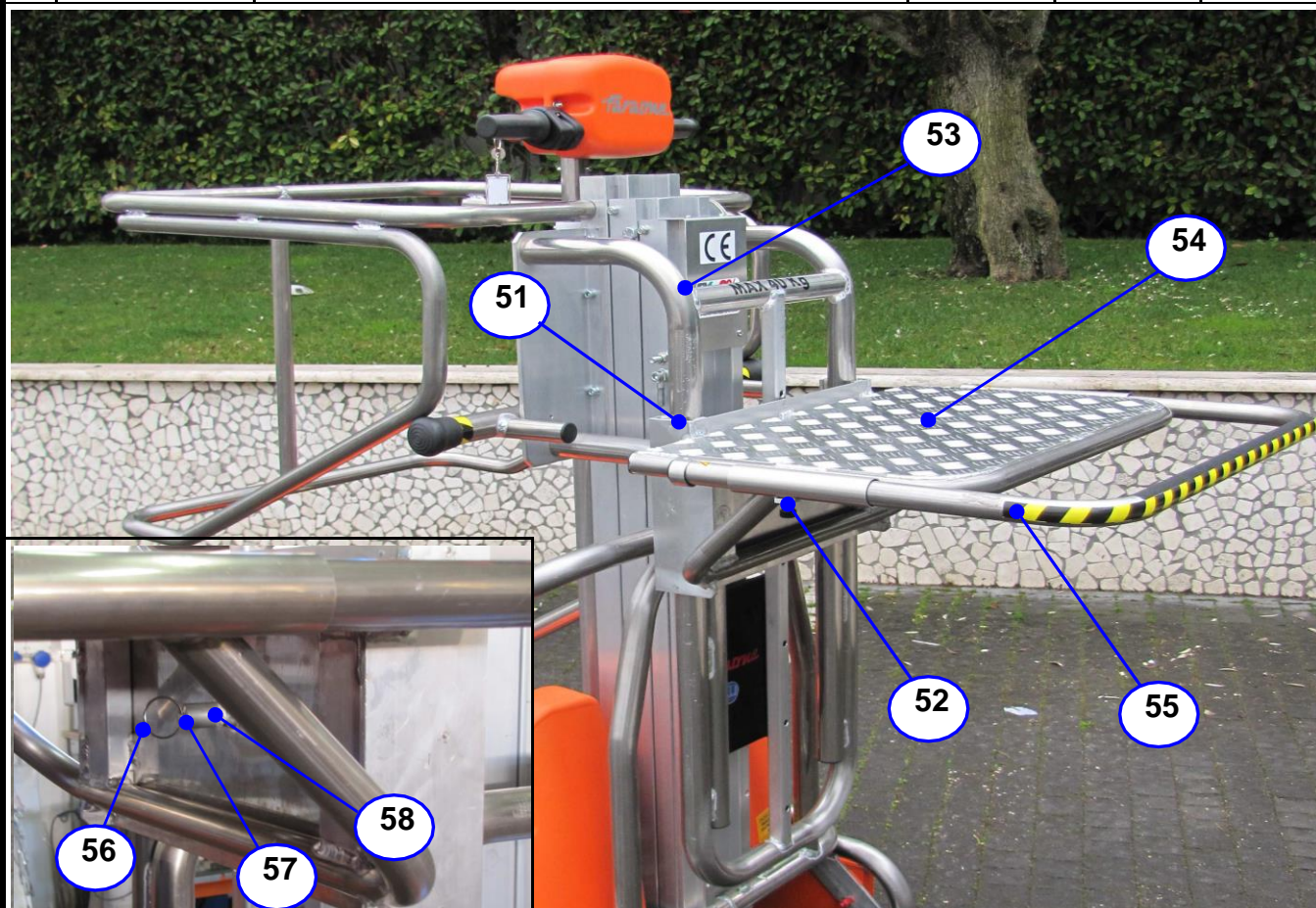



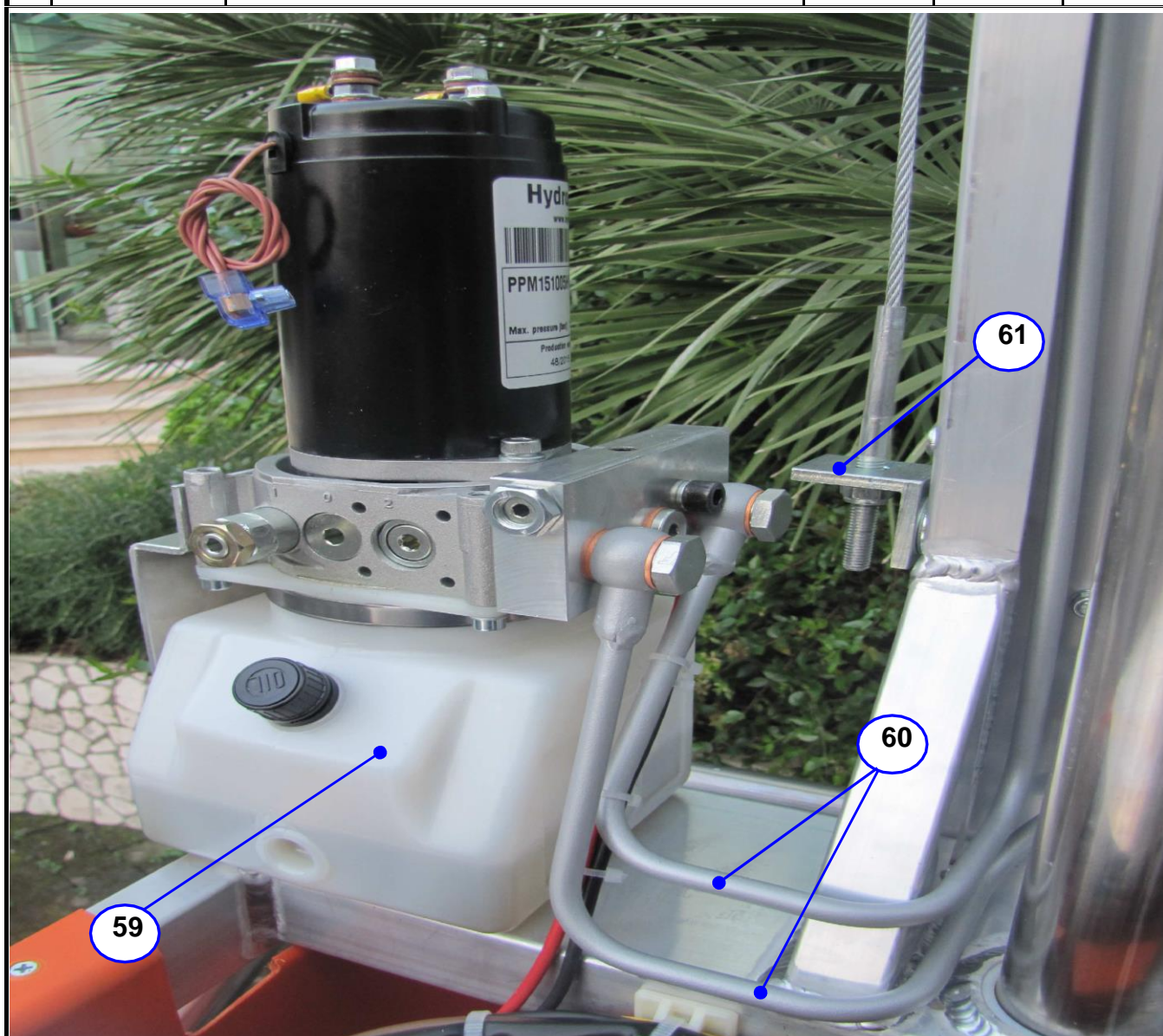

# ELEVAH40MOVE & ELEVAH40MOVE PICKING

N°	Codice:	Descrizione:			
59	2CENTR31	Centralina completa			
60	2TUBIDR8	Kit.Tubi idraulici			
61	2SUP.CAV	Supporto cavo			

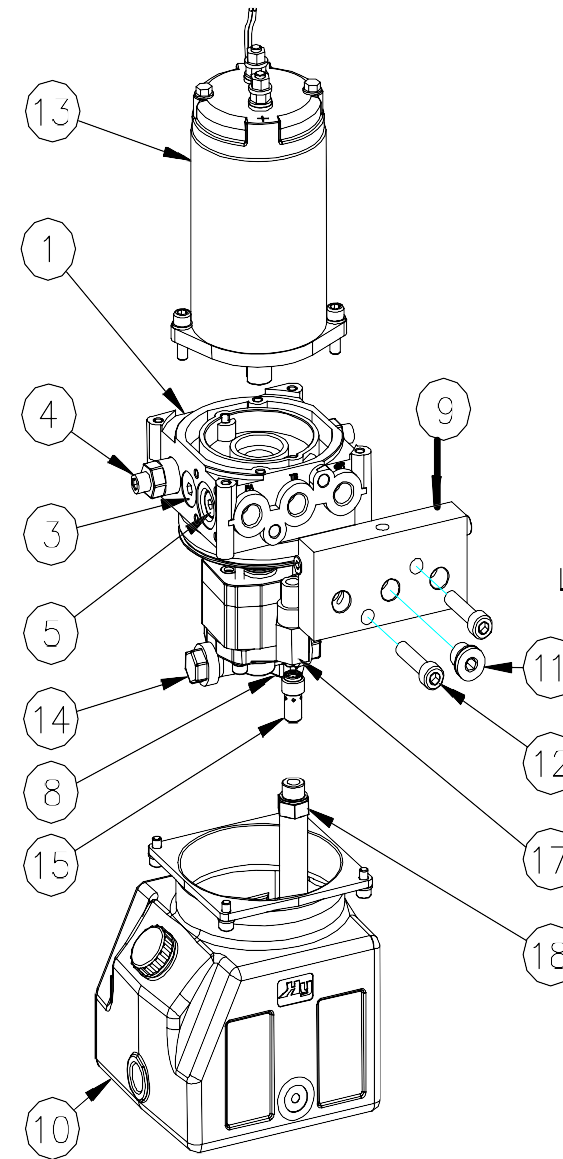
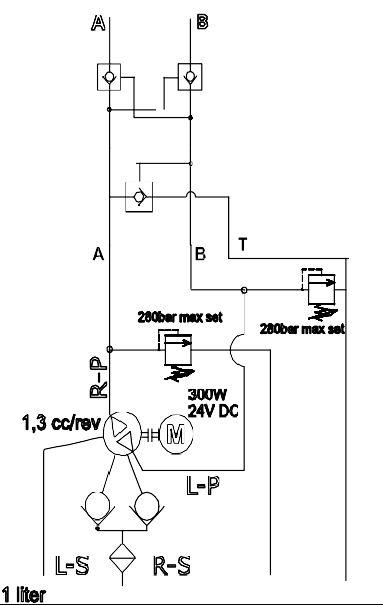

1	2	3	4	5	6																																																																												
			<table border="1" style="width:100%; border-collapse: collapse;"> <thead> <tr> <th>Pos</th> <th>Code</th> <th>Descriptor</th> <th>Q.ty</th> </tr> </thead> <tbody> <tr> <td>1</td> <td>MR</td> <td>micro PPM R type body for reversible pumps</td> <td>1</td> </tr> <tr> <td>2*</td> <td>E36200003</td> <td>coupling PPM Ø80 DC and AC integral motors with pumps gr 0 / EPB-114/125 with pump gr 1</td> <td>1</td> </tr> <tr> <td>3</td> <td>ML</td> <td>plug 5/8-18UNF basic</td> <td>1</td> </tr> <tr> <td>4</td> <td>DM_280</td> <td>relief valve M14 - 20±280 bar - socket screw adj.</td> <td>2</td> </tr> <tr> <td>5</td> <td>JP</td> <td>check valve poppet type 5/8-18UNF</td> <td>2</td> </tr> <tr> <td>6*</td> <td>PIL5818DIF</td> <td>valve for differential cylinders for PPM</td> <td>1</td> </tr> <tr> <td>7*</td> <td>C34100100</td> <td>standard suction strainer filter for PPM</td> <td>1</td> </tr> <tr> <td>8</td> <td>SFEP01D</td> <td>relief valve standard return dumpener</td> <td>2</td> </tr> <tr> <td>9</td> <td>M60403050</td> <td>modular manifold with emergency screw</td> <td>1</td> </tr> <tr> <td>10</td> <td>1TV</td> <td>1l square plastic tank vertical for PPM + filler &amp; breather plug</td> <td>1</td> </tr> <tr> <td>11</td> <td>PO1</td> <td>1/4 BSPP plug with copper washer</td> <td>1</td> </tr> <tr> <td>12</td> <td>TCEIM8X35</td> <td>head cap screw with hexagon socket ISO4762 DIN 912 burnished steel cl. 8.8</td> <td>2</td> </tr> <tr> <td>13</td> <td>0,3 24DC_T</td> <td>24VDC motor 300W Ø 80 + thermal switch</td> <td>1</td> </tr> <tr> <td>14</td> <td>RM1,3</td> <td>reversible gear pump - 1,25 cc/rev</td> <td>1</td> </tr> <tr> <td>15</td> <td>1(01)</td> <td>fixed pressure compensated flow control valve 1/4 BSPP 1l/min</td> <td>1</td> </tr> <tr> <td>16*</td> <td>ORF0101</td> <td>male 1/4G - female 1/4G</td> <td>1</td> </tr> <tr> <td>17</td> <td>CMFVSC01-S01</td> <td>Hexagonal column 1/4 M - 1/4 F</td> <td>1</td> </tr> <tr> <td>18</td> <td>PP0180</td> <td>suction line pipe 1/4 BSPP 80mm</td> <td>1</td> </tr> </tbody> </table>			Pos	Code	Descriptor	Q.ty	1	MR	micro PPM R type body for reversible pumps	1	2*	E36200003	coupling PPM Ø80 DC and AC integral motors with pumps gr 0 / EPB-114/125 with pump gr 1	1	3	ML	plug 5/8-18UNF basic	1	4	DM_280	relief valve M14 - 20±280 bar - socket screw adj.	2	5	JP	check valve poppet type 5/8-18UNF	2	6*	PIL5818DIF	valve for differential cylinders for PPM	1	7*	C34100100	standard suction strainer filter for PPM	1	8	SFEP01D	relief valve standard return dumpener	2	9	M60403050	modular manifold with emergency screw	1	10	1TV	1l square plastic tank vertical for PPM + filler & breather plug	1	11	PO1	1/4 BSPP plug with copper washer	1	12	TCEIM8X35	head cap screw with hexagon socket ISO4762 DIN 912 burnished steel cl. 8.8	2	13	0,3 24DC_T	24VDC motor 300W Ø 80 + thermal switch	1	14	RM1,3	reversible gear pump - 1,25 cc/rev	1	15	1(01)	fixed pressure compensated flow control valve 1/4 BSPP 1l/min	1	16*	ORF0101	male 1/4G - female 1/4G	1	17	CMFVSC01-S01	Hexagonal column 1/4 M - 1/4 F	1	18	PP0180	suction line pipe 1/4 BSPP 80mm	1
Pos	Code	Descriptor	Q.ty																																																																														
1	MR	micro PPM R type body for reversible pumps	1																																																																														
2*	E36200003	coupling PPM Ø80 DC and AC integral motors with pumps gr 0 / EPB-114/125 with pump gr 1	1																																																																														
3	ML	plug 5/8-18UNF basic	1																																																																														
4	DM_280	relief valve M14 - 20±280 bar - socket screw adj.	2																																																																														
5	JP	check valve poppet type 5/8-18UNF	2																																																																														
6*	PIL5818DIF	valve for differential cylinders for PPM	1																																																																														
7*	C34100100	standard suction strainer filter for PPM	1																																																																														
8	SFEP01D	relief valve standard return dumpener	2																																																																														
9	M60403050	modular manifold with emergency screw	1																																																																														
10	1TV	1l square plastic tank vertical for PPM + filler & breather plug	1																																																																														
11	PO1	1/4 BSPP plug with copper washer	1																																																																														
12	TCEIM8X35	head cap screw with hexagon socket ISO4762 DIN 912 burnished steel cl. 8.8	2																																																																														
13	0,3 24DC_T	24VDC motor 300W Ø 80 + thermal switch	1																																																																														
14	RM1,3	reversible gear pump - 1,25 cc/rev	1																																																																														
15	1(01)	fixed pressure compensated flow control valve 1/4 BSPP 1l/min	1																																																																														
16*	ORF0101	male 1/4G - female 1/4G	1																																																																														
17	CMFVSC01-S01	Hexagonal column 1/4 M - 1/4 F	1																																																																														
18	PP0180	suction line pipe 1/4 BSPP 80mm	1																																																																														
A	B		A																																																																														
B	C		B																																																																														
C	D		C																																																																														
D	D		D																																																																														
1	2	3	4	5	6																																																																												

D1		MODIFICHE		FIR.	DATA
I.R.					
Materiale	UNI	 via Pastrengo 62 Varedo (MB) Italy	Tratt. termico	UNI	
Dimensioni	UNI		Tratt. superficiale	UNI	
Stato	UNI		Durezza		
Disegnato	L. Cortese	15/12/2015			
Controllato	W. Dia	15/12/2015			
Approvato			Denominazione		
 Scala		Gruppo	Codice		I.R.
Varedo (MB) - Italy			PPM151005HY-FARAONE-162252		00
<small>                     Finisci non quotati: Sm 12x40°                      Raggio non quotati: 0,4 max                      Tolleranze per dimensioni lineari, angolari e tolleranze geometriche give di indicatori di tolleranza specifici:                      UNI EN 22768-2:1996 - mK                      Filatura Madre Vite                      Metrica: G1 G2 G3                      Gas: H A                      A.S.A.: 2B 2A                 </small>			Documento riservato a termini di legge		

ESPLOSO CENTRALINA OLEODINAMICA  
 ELEVAH40MOVE & ELEVAH40MOVE PICKING